

FIG. 1

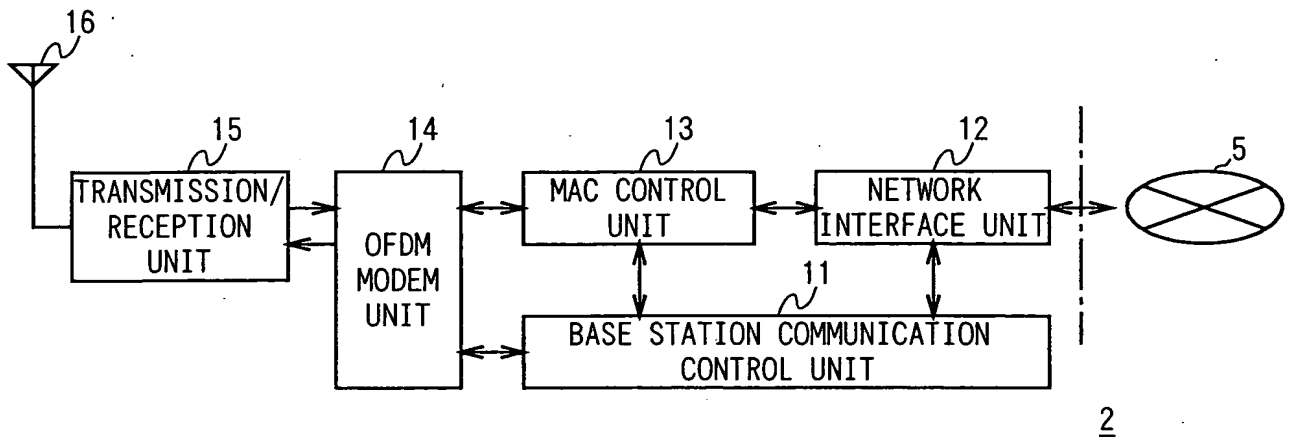

FIG. 2

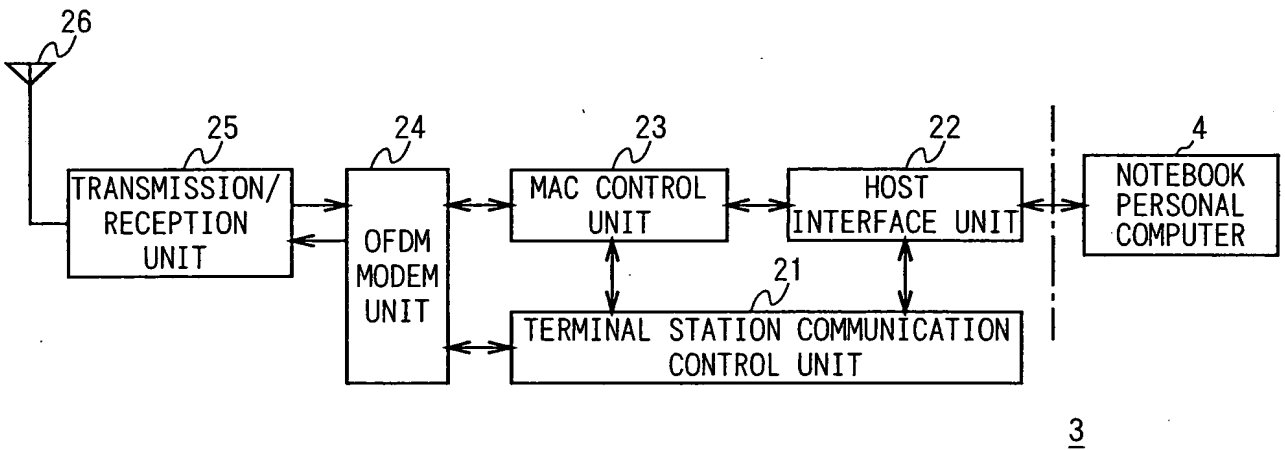

FIG. 3

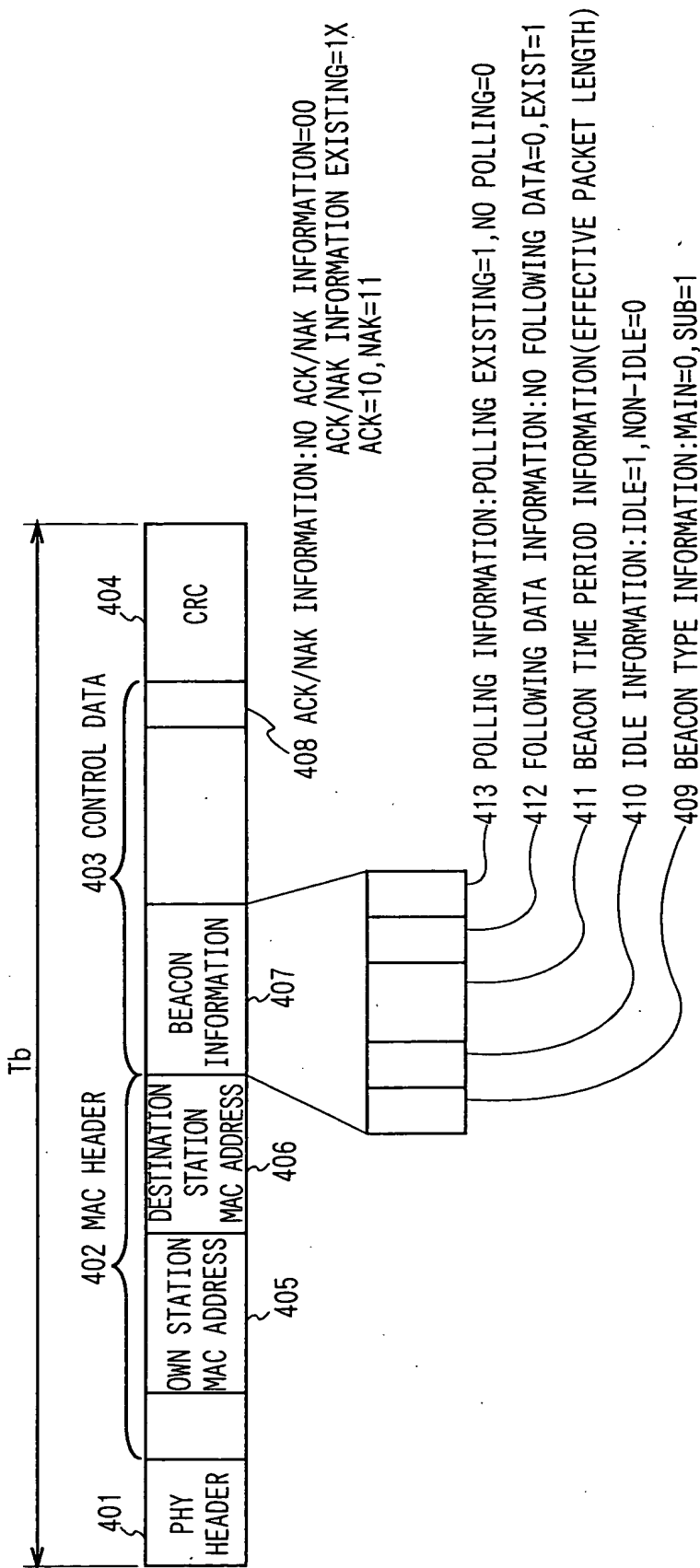

FIG. 4

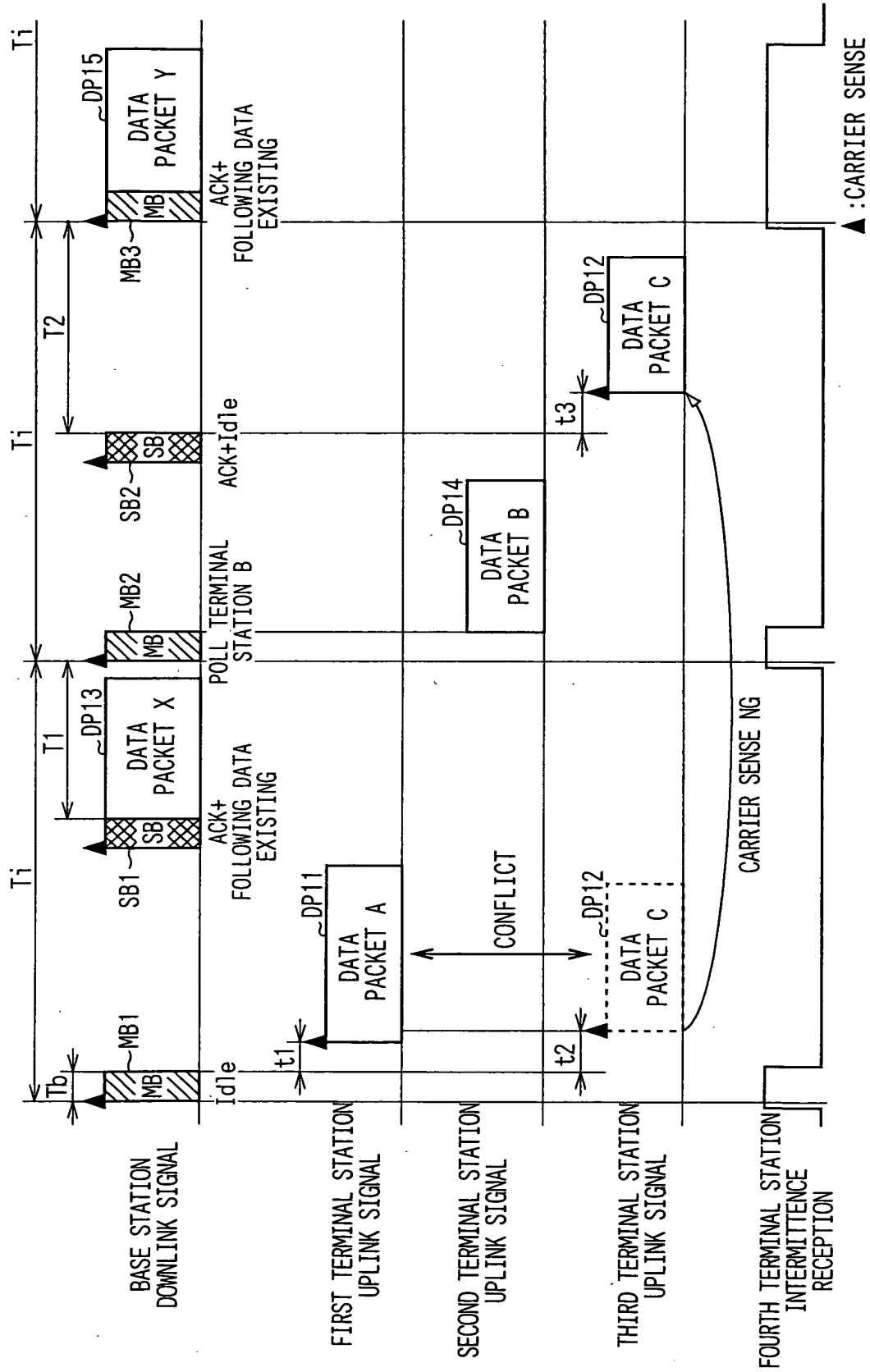

FIG. 5

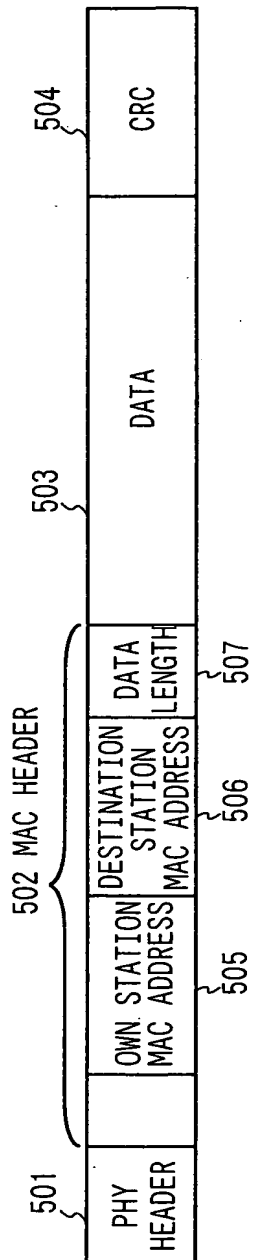

FIG. 6

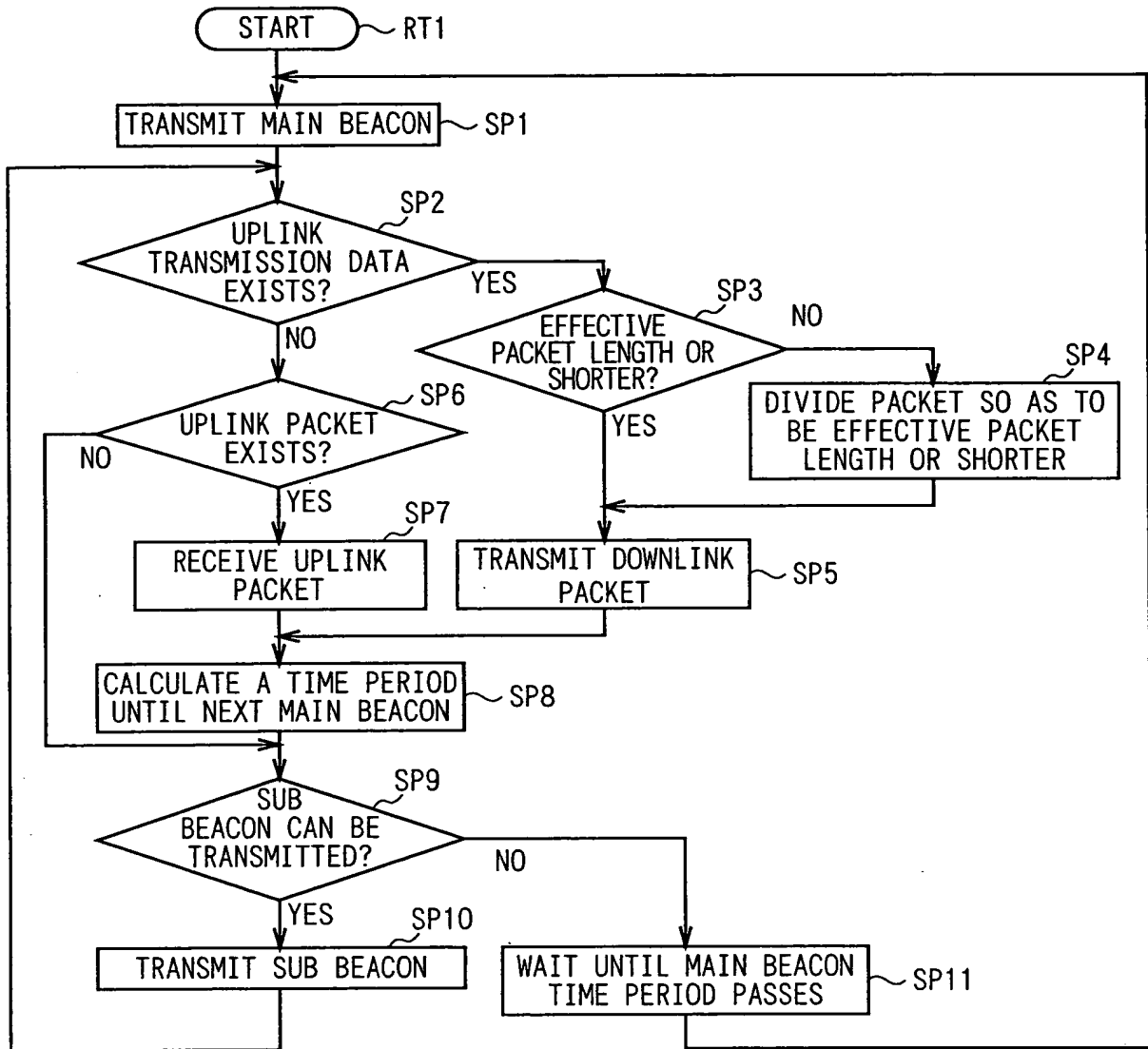

FIG. 7

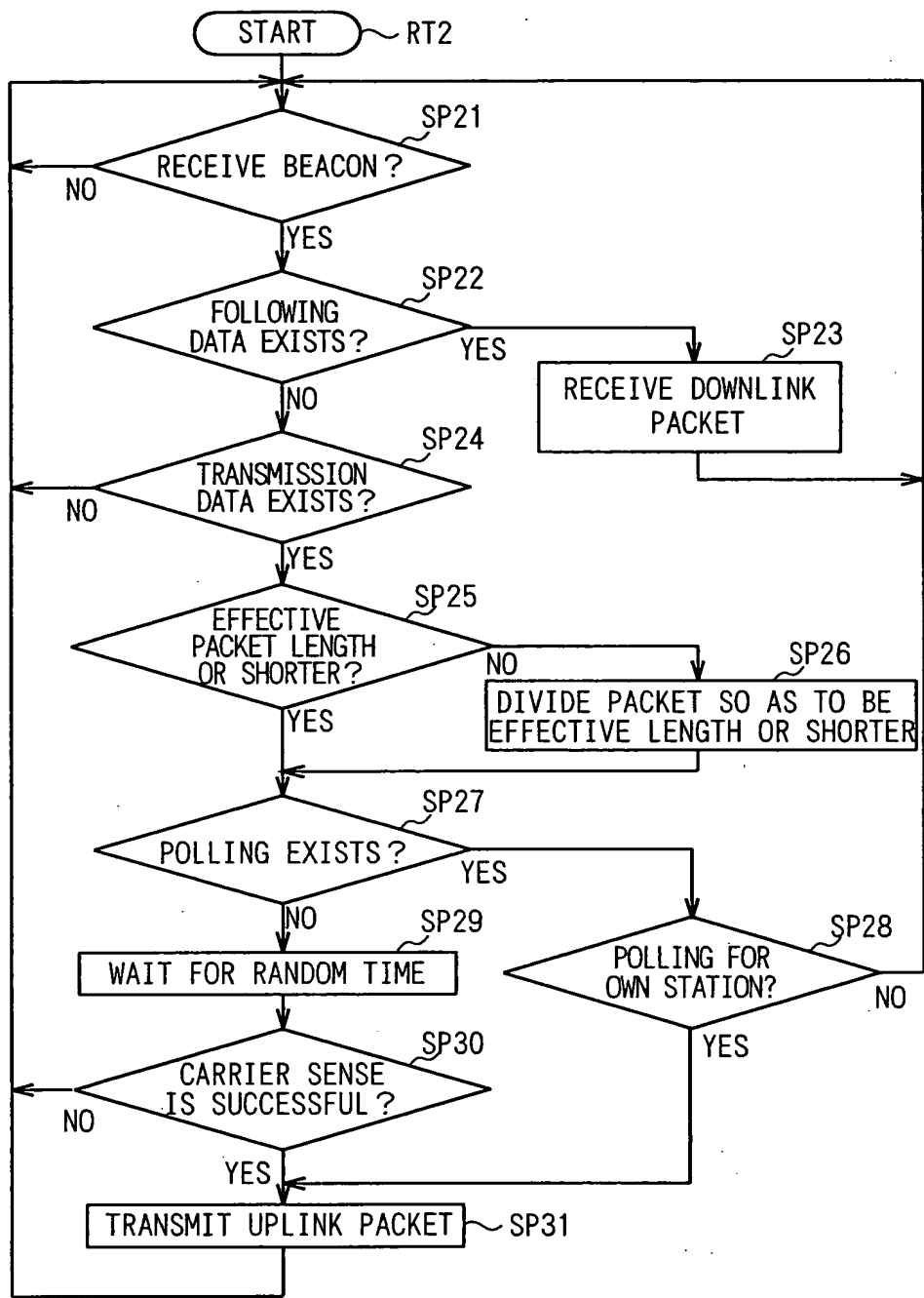

FIG. 8

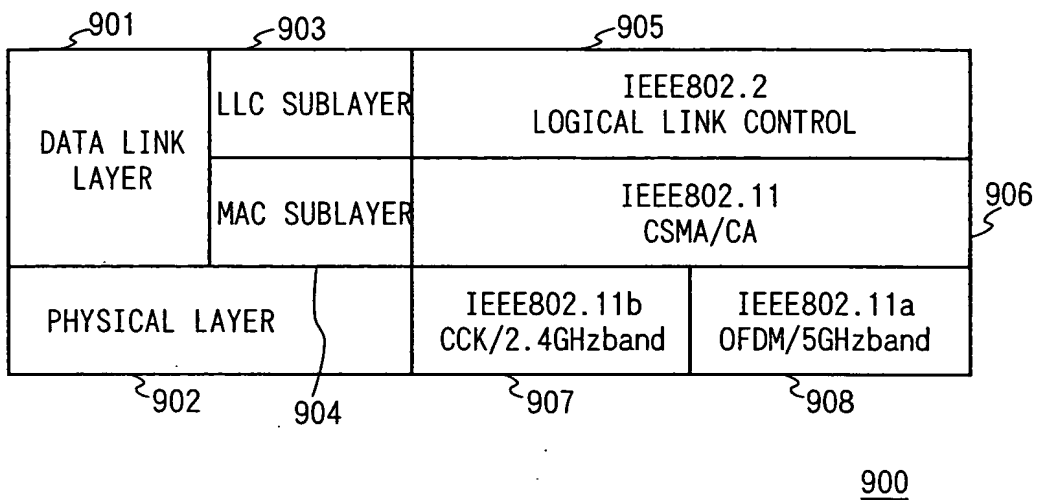

FIG. 9

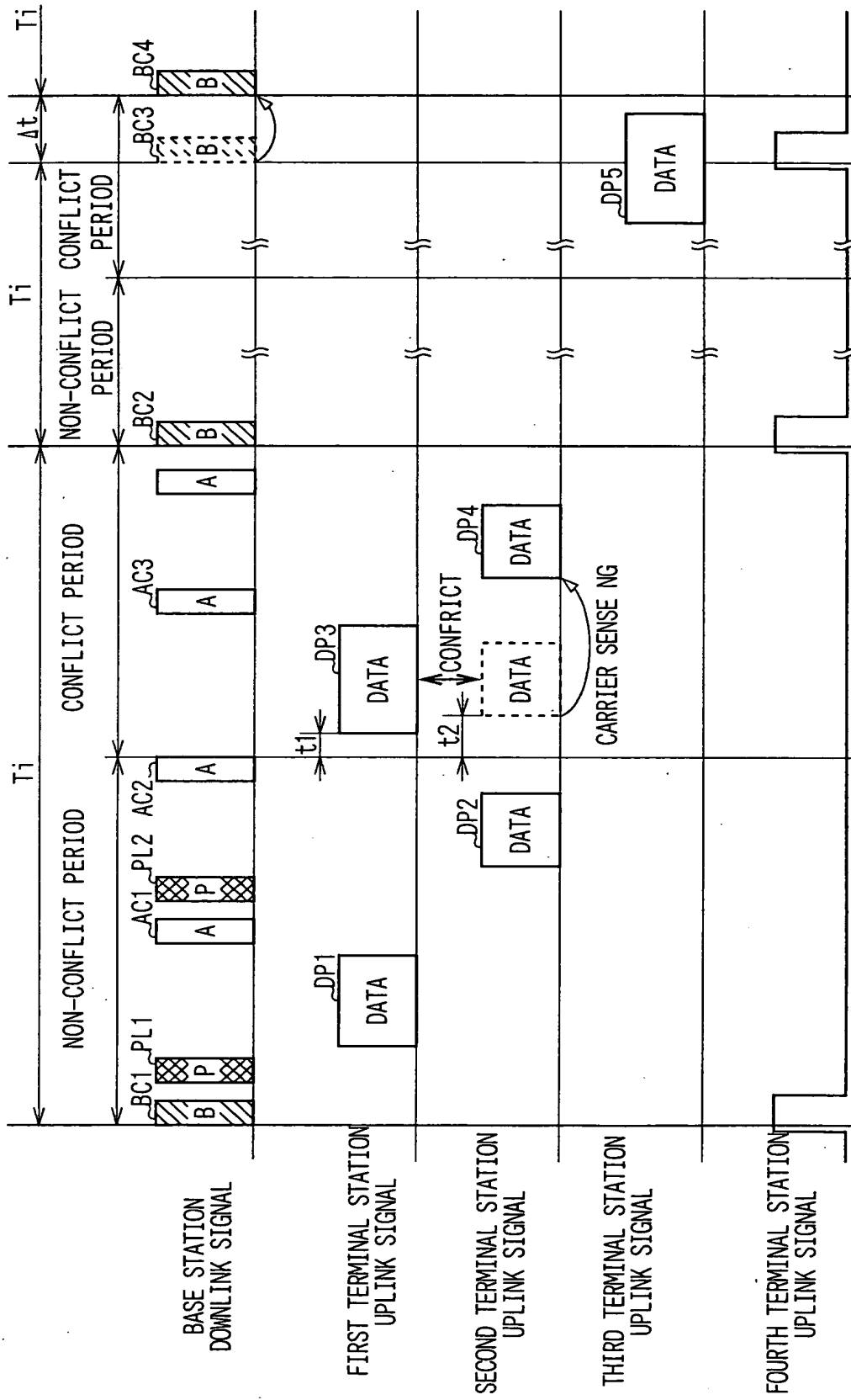

FIG. 10

DESCRIPTION OF REFERENCE NUMERALS

1...WIRELESS LAN SYSTEM, 2...BASE STATION, 3...TERMINAL STATION,
4...NOTEBOOK PERSONAL COMPUTER, 5...EXTERNAL NETWORK, 11...BASE STATION
COMMUNICATION CONTROL UNIT, 12...NETWORK INTERFACE, 13, 23...MAC CONTROL
UNIT, 14, 24...OFDM MODEM UNIT, 15, 24...TRANSMISSION/RECEPTION UNIT,
16, 26...ANTENNA, 21...TERMINAL STATION COMMUNICATION CONTROL UNIT,
22...HOST INTERFACE UNIT.